

Nexus™ Systems

READY → SET → INJECT

mastip™
hot runner solutions



Mastip's next generation Nexus™ Pre-Assembled and Pre-Wired Systems are delivered as a complete turn-key solution for quick and simple installation.

Nexus™ Systems incorporate the advanced leak protection of FlowLoc™ Technology and benefits from a superior thermal profile providing a wide moulding window for a broad range of polymers.

Applications

- Ideal for small to medium automotive, medium to large appliances and large part electrical applications
- Able to process both commodity and abrasive engineering grade polymers
- Fully customisable to suit your application requirements
- Suitable for high pressure applications

Features

- Fast and simple installation out of the box, no further assembly required
- Thermal and Valve Gate configurations
- High Temperature Valve Cylinders, hose and fittings
- Customisable wiring frame to match specific mould layout
- FlowLoc™ Technology nozzle range attaches securely to the manifold with a threaded connection
- Cylix™ Valve Cylinders mount directly to the manifold system
- FlowLoc™ Technology is available in 16, 19 and 27 Series Thermal or Valve Gate nozzles

Benefits

- Advanced heating technology for superior thermal performance
- FlowLoc™ Technology provides a leak-proof solution
- Thermally stabilized Valve Cylinders
- User-friendly maintenance and easy serviceability due to quick removal of complete unit from mould
- Excellent thermal profile ensuring a wide moulding window
- Cold condition starting without the risk of polymer leakage

Nexus™ Systems

READY → SET → INJECT



Nexus™ systems are designed for fast, simple installation out of the box without requiring any further assembly.

Nexus™ systems feature fully customisable frames, electrical connections, tip and nut options and nozzle lengths to suit your application requirements.

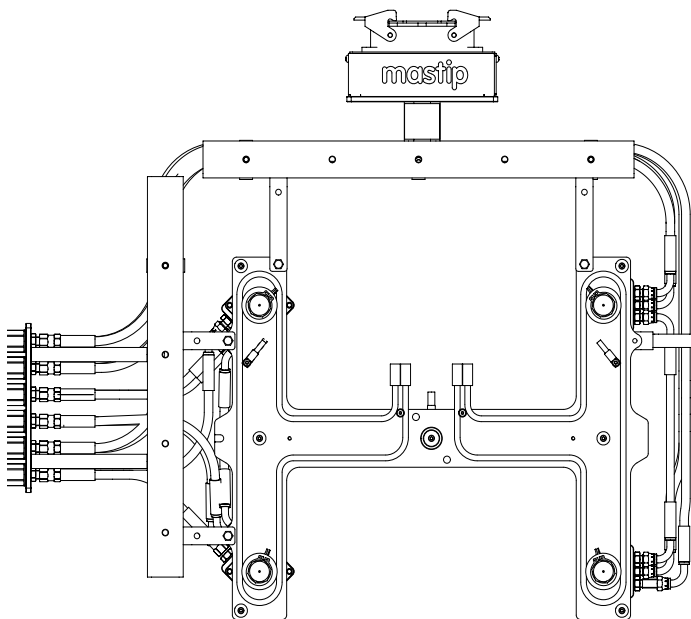
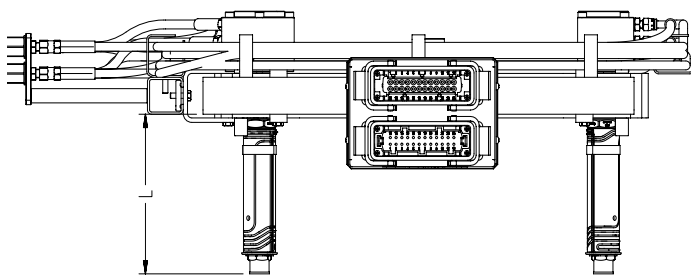

Cylix™ Valve Gate Actuation

The Cylix™ Cylinder features Pneumatic Valve actuation in a thermally stabilized system mounted directly to the manifold. With the ability to adjust valve pin height and incorporating long life seals and bearings, it is the optimal solution for precise control of your moulding requirements.

Cylix™ Actuator



FlowLoc™ Technology Nozzle Range Overview

The FlowLoc™ nozzle range features a threaded base that attaches to the manifold providing a secure, leak-proof operation. FlowLoc's™ advanced heating technology delivers superior thermal performance for a wide moulding window.

FlowLoc™ Range



Availability

	16 Series	19 Series	27 Series
	FlowLoc™ Technology Nozzle Range		
L		75	
		95	
		115	
		130	
		145	
		175	
		-	-
	-	-	275

All measurements are in millimetres.